



Model NB10-2-120A
 Variable Speed Ventilating Hot Water
 Air Handler, Horizontal or Upflow

Heating to 60,000 Btuh • Cooling to
 5 tons • Vent Cooling to 2200 cfm

NIGHTBREEZE^â

**INSTALLATION
 INSTRUCTIONS**

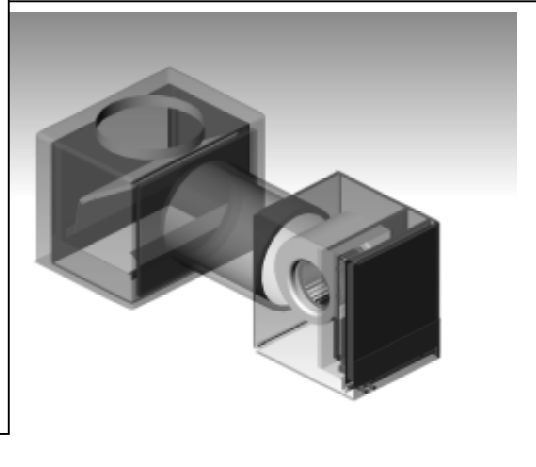

TABLE OF CONTENTS

Product Description	2	Installation	10
Air Handler Damper	2	Preparation & Scheduling	10
Controls	2	Air Handler	11
Description of Operation.....	2	Damper	11
Specifications	4	Wiring.....	12
Equipment Placement & Sizing	5	Pump Selection & Installation.....	14
Damper & Air Handler Locations	5	Piping	14
Outside Air Intake.....	5	Control Setup	15
Duct and Register Sizing	5	Advanced Settings.....	15
Dimensions & Clearances	6	Basic User Settings	17
Damper Placement	8	Startup	17
Systems Requiring Multiple Return.....	8	Trouble Shooting	20
Cooling Coil & Condenser Sizing.....	9	Standard Limited Product Warranty	21
Heat Source Sizing	9		
Hot Water Piping.....	10		
Control Placement.....	10		

IMPORTANT NOTES TO INSTALLER

- Review these instructions thoroughly prior to beginning installation.
- Installation of the NightBreeze system must conform to local building, mechanical, and plumbing codes.
- Before attempting to perform any service or maintenance, turn the electrical power to unit off at the disconnect switch.
- Provide these instructions to the owner for future reference.

PRODUCT DESCRIPTION

Air Handler

NightBreeze is a residential comfort system that integrates heating, cooling, ventilation cooling, and fresh air ventilation to provide exceptional indoor comfort and air quality. The horizontal/upflow air handler incorporates a variable speed blower powered by a G.E. ICM2 motor, a hot water heating coil, and controls. The blower motor is programmed to deliver a constant airflow rate over a wide range of external static pressures, and provides full variable speed operation (200 - 2100 CFM) in heating mode. The heating coil is connects to a water heater or boiler and a circulating pump delivers hot water to the coil. DX cooling coils from 1½ to 5 tons may be added.

Damper

An automatic damper couples to the air handler and allows the system to ventilate using 100% outside air. The damper, which installs above the return air opening in the ceiling, also vents indoor air to the attic. A duct connects the damper to a louver or roof vent to provide the fresh air supply.

Controls

Controls provided with the NightBreeze system include a microprocessor-based thermostat, an outdoor temperature sensor, and an electronic control module (installed in the air handler). The thermostat allows separate temperature settings for cooling, heating, and vacation operating modes. The thermostat also provides for short-term (override) settings and manual fan operation. All settings are preserved during power losses by a capacitor. Consult the Owner's Manual for additional information on control operation.

Instead of using speed taps at the air handler to set heating and cooling airflow rates, all settings are made at the thermostat. Pressing and holding the two up/down adjustment buttons at the same time will display the Advanced Settings menu. These settings can then be selected using the up/down buttons. Refer to **Control Setup** for information on all settings.

Description of Operation

NightBreeze controls allow four operating modes: *Off*, *Cooling*, *Heating*, and *Vacation*. These and other control functions are described below.

Cooling: During the cooling season the air handler ventilates the house with 100% outside air when it is 5° cooler¹ outdoors than indoors (usually at night). The damper draws in outside air and relieves indoor air through the return air grille.

The ventilation cooling airflow rate varies daily with cooling load and is updated each day at midnight. The control records indoor and outdoor temperatures from prior days, and uses this history to predict temperatures for the next day. The predicted indoor temperature range is indicated by the shaded portion of the thermostat's "comfort bar" (press *Set* to view). If hotter weather is predicted, the fan operates at higher speeds. The spacing between the shaded bar and the "Hi" setting is one indicator of how fast the fan will run. If the shaded bar touches or crosses the "Hi" setting, the fan will likely run at the speed selected under "Vent Fan CFM" in Advanced Settings.

A low limit temperature setting prevents the house from being overcooled during mild weather. If ventilation cooling is not sufficient to prevent the indoor temperature from exceeding the high limit temperature setting, the system operates the split-system air conditioner, if one is provided. If it is cooler outdoors than indoors while the air conditioner is operating, the damper operates as an economizer, selecting outside air instead of return air. If an air conditioner is installed, the air conditioning airflow rate must be properly set using the Advanced Settings menu and Cooling Mode must be set to "Standard".

Heating: The circulating pump circulates hot water from the boiler or water heater to the built-in coil. The blower delivers warm air at a rate proportional to the heating demand. Maximum airflow is delivered when the indoor temperature is 5° below the thermostat setting, and airflow decreases as the air temperature approaches the thermostat setting.

Vacation: If Vacation mode is selected the system maintains indoor temperatures between low and high temperature settings, automatically switching between heating and cooling modes as needed. Cooling is provided by outside air ventilation when it is cooler outdoors than indoors, and by the split-system air conditioner when it is not.

Heating Mode Fresh Air Ventilation: While the system is in heating mode, the outside air damper and fan operate once per hour to provide fresh air ventilation. If the heating system operates at any time during a given hour, the damper will open long enough to deliver the average hourly ventilation rate, which is set at the thermostat using the Advanced Settings menu. The length of time the damper is open varies with blower speed to maintain the proper level of ventilation. For example, if heating demand is high and the fan is running at a high speed, the damper will not stay open as long. If the supply air temperature drops below about 100°, the damper will close to prevent discomfort from cold drafts.

If the fresh air requirement is not fully satisfied while the system is providing heating, or if no heating is needed during the hour, the system waits until the end of the hour to activate the fan and damper. It will then operate the fan to deliver outside air at a rate of about 200 CFM for the required duration. At outside temperatures below 45° the control will automatically activate the pump to temper outside air. At outside temperatures below 35°, fresh air ventilation is discontinued to prevent the possibility of freezing the heating coil in the event of a pump failure. Fresh air ventilation can be turned off by setting *Ventilation Rate* to 0 in Advanced Settings.

¹ The 5° temperature differential can be modified in the Advanced Settings menu.

SPECIFICATIONS

Table 1 BLOWER DATA						
CFM vs. EXTERNAL STATIC PRESSURE						
CFM*	0.10	0.20	0.30	0.40	0.50	0.60
200	326	232	-	-	-	-
400	530	450	450	404	-	-
600	596	596	616	596	596	653
800	739	770	800	815	829	871
1000	924	949	974	1056	1033	1044
1200	1100	1111	1163	1213	1232	1261
1400	1307	1343	1403	1436	1436	1477
1600	1540	1548	1578	1608	1615	1637
1800	1715	1763	1783	1803	1835	1854
2000	1936	1984	2008	2026	2060	2072
2200	2151	2139	2125	2105	2089	2083

*CFM value selected in thermostat *Advanced Settings*

Table 2 HEATING PERFORMANCE DATA*				
MBH at Entering Water Temperature				
CFM	120	130	140	150
600	20.1	26.2	30.3	36.1
800	26.1	30.9	38.0	43.2
1000	29.3	34.8	43.3	51.3
1200	32.0	41.2	50.1	58.9
1400	34.3	44.5	54.5	64.3
1600	39.9	50.3	60.8	69.1

*At 65° entering air temperature and flow rates listed in Table 3.

Table 3 WATER FLOW AND PRESSURE DROP		
Heating Capacity, MBH	Minimum Water Flow, GPM	Coil Water Pressure Drop, feet w.c.
20 - 25	2	0.16
26 - 35	3	0.33
36 - 45	4	0.54
46 - 55	5	0.81
56 - 70	6	1.11

Table 4 ELECTRICAL RATINGS*		
Blower CFM	Amps**	Watts
400	0.2	20
800	1.3	160
1000	1.7	213
1200	2.8	302
1400	3.8	453
1600	4.9	588
1800	6.6	754
2000	10.0	856
2200	10.5	895
Circulating Pump***	1.3	213

*All at 0.4" external static pressure, except 400 CFM measured at 0.04".

**At 115V

***For Taco 009BF-5

Weights: Air Handler Cabinet with heating coil: 120 lbs.
Damper: 60 lbs.

EQUIPMENT PLACEMENT & SIZING

Damper and Air Handler Locations and Duct Requirements

The NightBreeze air handler may be installed in any location, but should be as close to the damper as possible to minimize pressure and thermal losses. The damper mounts directly over the ceiling return grille, which should be located in an accessible location over a hallway, since access to the damper is required for filter replacement. Refer to *Dimensions and Clearances* for air handler and damper space and clearance requirements.

If multiple return air grilles are installed the outside ventilation air will be diluted by return air, diminishing the ventilation cooling effectiveness. Refer to page 8 for alternative ducting approaches to avoid this problem.

Outside Air Intake Location

Outside air must be ducted from an intake location to the damper as shown in Figure 1. Use either a gable-mounted louver, a dormer vent, or false chimney with suitable vent cap for the outside air intake. Refer to Table 5 for required free area.

Duct and Register Sizing

The recommended airflow rate for ventilation cooling is 0.6 CFM per ft² of floor area. Ducts should be sized using the Manual J airflow rate or 0.6 CFM per ft², whichever is greater. Recommended minimum sizes for outside air and return duct mains are indicated in Table 5. Size branch ducts and registers by apportioning the recommended ventilation rate from the table according to room or zone load, and using a maximum external static pressure of 0.3" w.c.

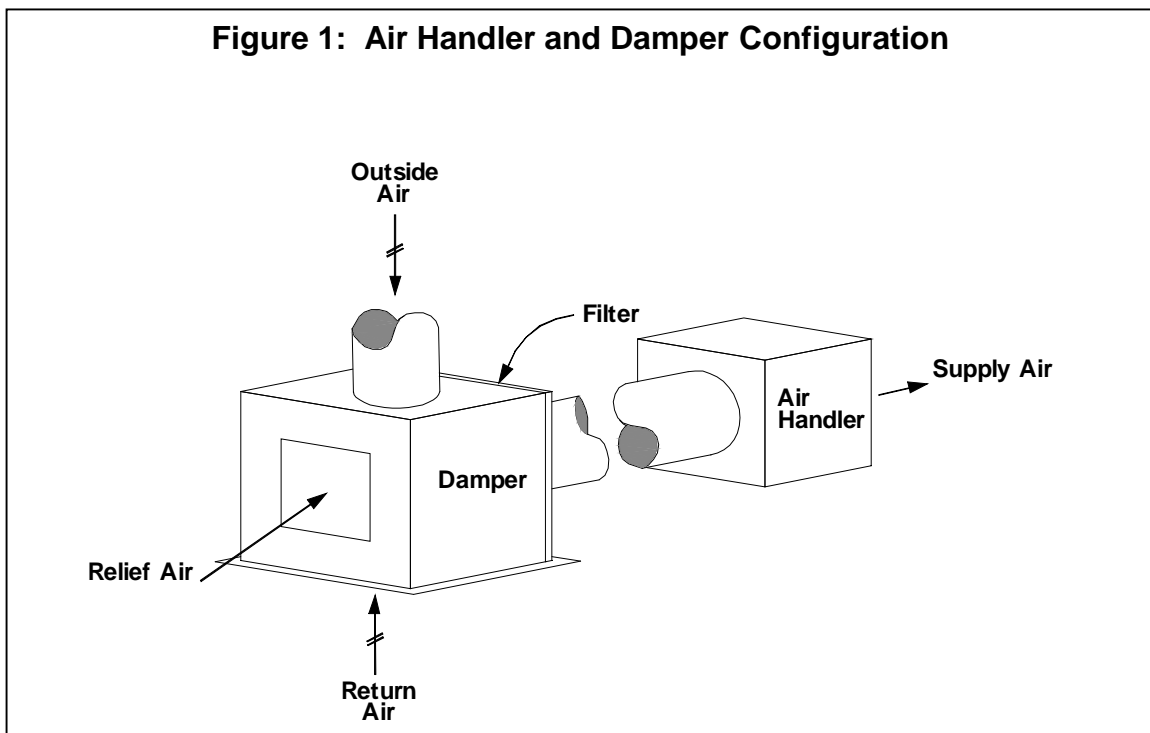

Table 5 DUCT SIZING RECOMMENDATIONS			
House Floor Area	Recommended Maximum Ventilation Airflow	Minimum Duct Size	Vent Intake Minimum Free Area, ft ²
Up to 1400 ft ²	800 CFM	14"	1.00
1400 - 1800 ft ²	1000 CFM	16"	1.25
1800 - 2200 ft ²	1300 CFM	18"	1.63
2200 - 2600 ft ²	1600 CFM	20"	2.00
2600 - 3000 ft ²	1800 CFM	20"	2.25

Dimensions and Clearances

Dimensions for the air handler are shown in Figure 2 and for the damper in Figure 3. Provide at least 36" clearance to the air handler access panel to allow for servicing the blower and coil, and access to the damper where the drive motor is mounted and to the gravity damper flap. Zero clearance is permitted to all other air handler and damper surfaces.

Figure 2: Air Handler Dimensions

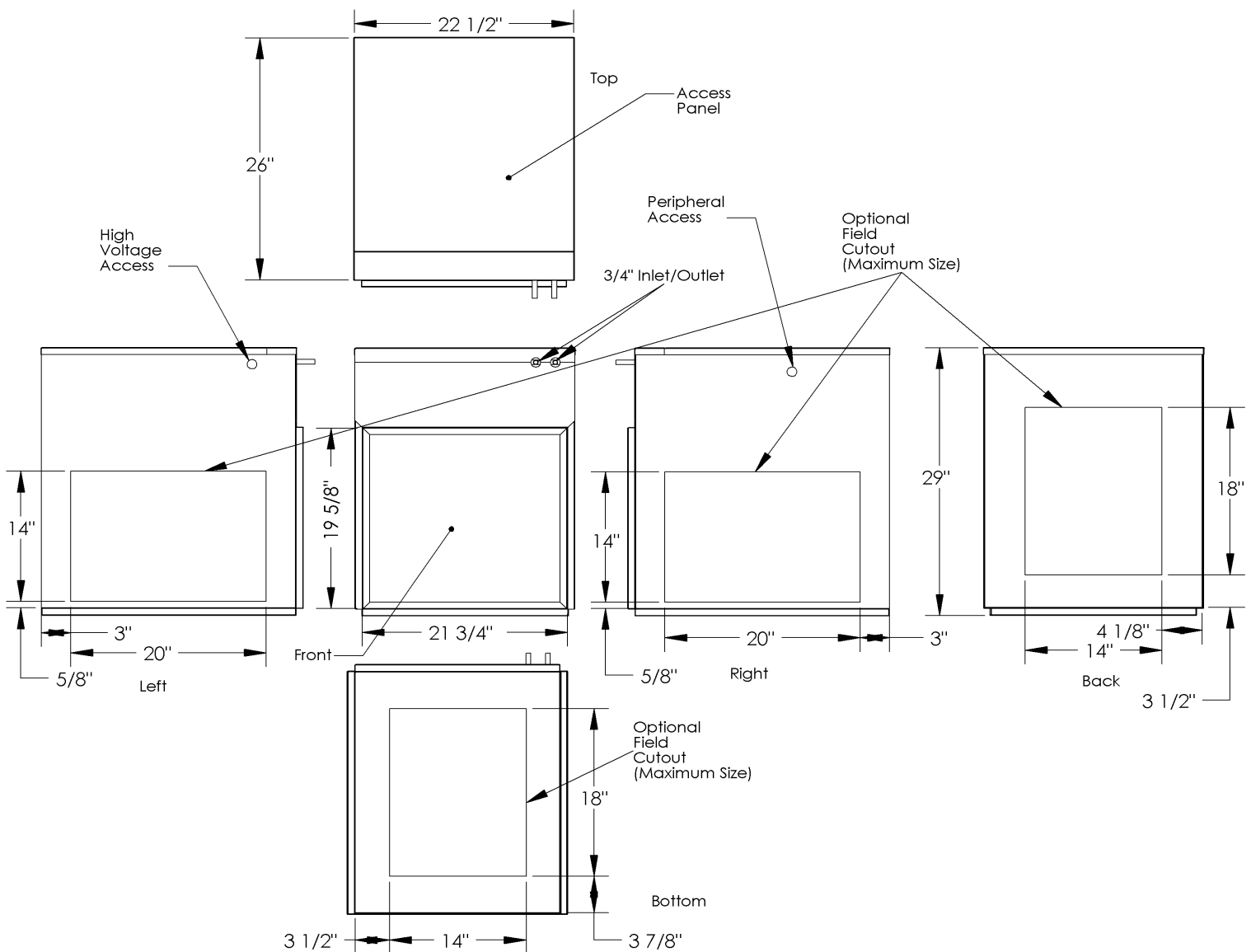
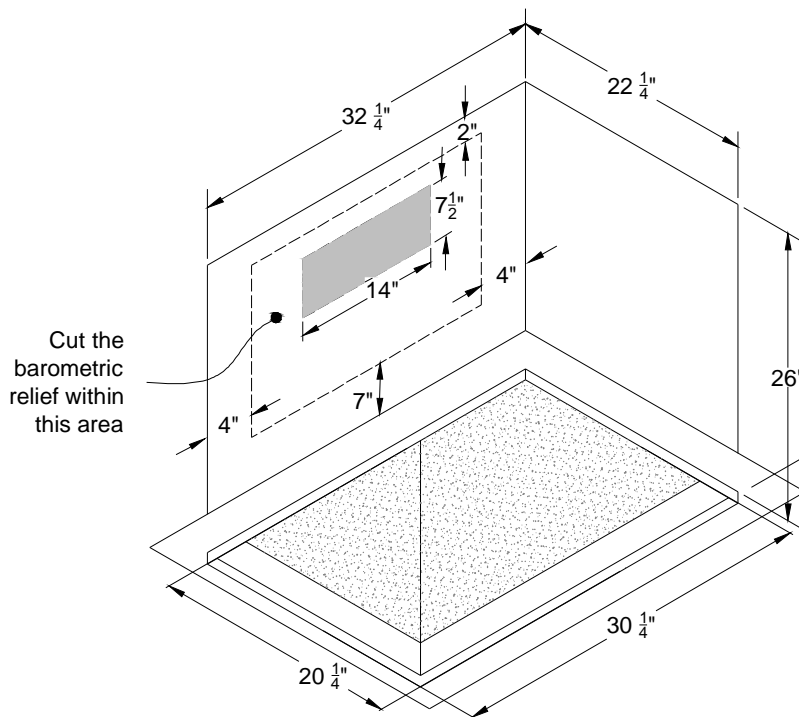
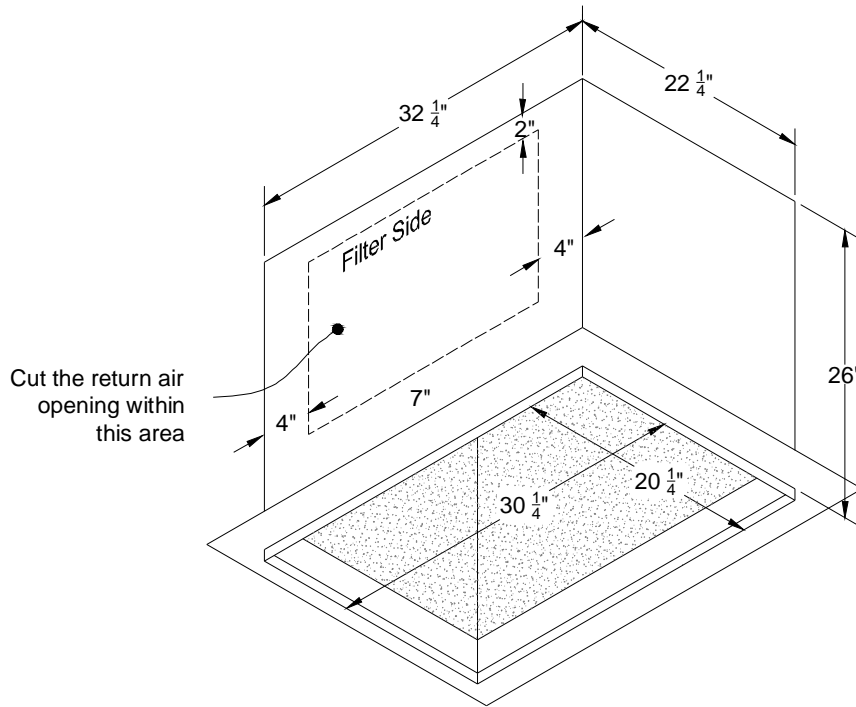

Figure 3: Damper Dimensions



Damper Placement

The outside air damper should be located in the attic, central to supply air registers, and immediately above the return air grille. Consult the manufacturer's representative for alternate mounting configurations. The damper requires two duct connections, one to the air handler and one to the outside air intake. If the damper is not installed in a space that is vented to outdoors, a relief duct will also be required. See Figure 1.

Systems Requiring Multiple Return Air Ducts/Grilles

It is good practice to provide separate return air to large rooms such as master bedrooms to prevent pressure imbalances between rooms when doors are closed. However, if returns are installed as shown in Figure 4 without a damper, outside air is diluted while the system is in ventilation cooling mode, significantly reducing the cooling effectiveness. There are three alternatives to eliminating this problem, represented by Figures 4, 5, and 6. The solution shown in Figure 4 is preferred because it provides better air distribution and does not make filter changing more difficult (as in Figure 6).

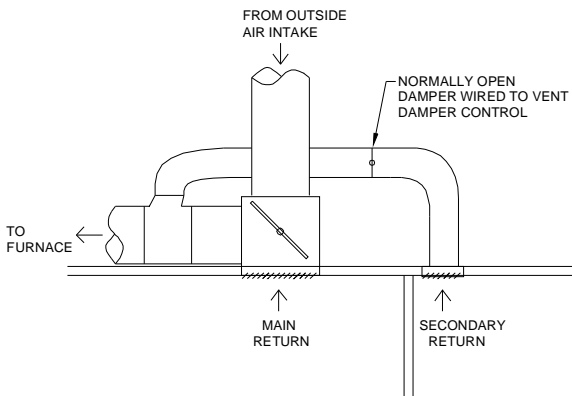

Figure 4: Motor Driven Return Air Damper in Secondary Return

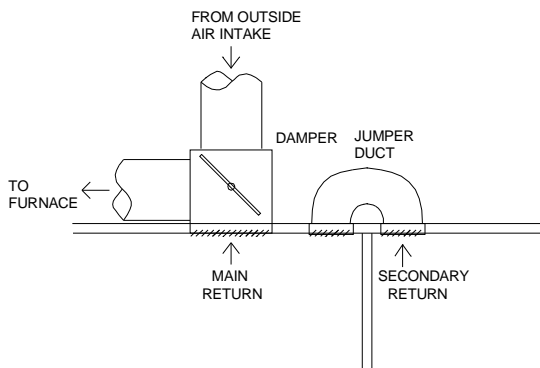

Figure 5: Jumper Duct

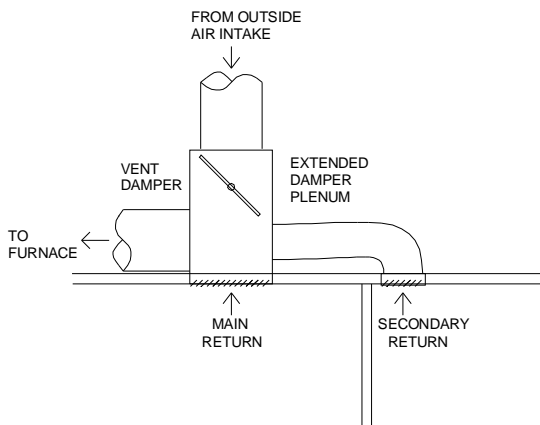

Figure 6: Extended Plenum Damper Box

Cooling Coil and Condenser Sizing

Air conditioners should be sized in accordance with ACCA Manuals J and S. Depending upon climate, house design, and control settings, NightBreeze may reduce cooling load by more than 5 Btu per square foot, thereby providing an extra safety margin on air conditioner sizing.

The NightBreeze air handler can be used with up to a 5 ton air conditioner. NightBreeze generally requires higher airflow rates for ventilation cooling than for air conditioning, so cooling coils should be oversized by at least one ton to minimize pressure drop (and fan energy use) while the system is ventilating. The larger coil will also improve air conditioner performance. The condensing unit should be located as close as possible to the air handler; refer to condenser manufacturer's instructions for refrigerant line sizing.

Table 6 COOLING COIL SIZING	
Condenser Size	Recommended Minimum Cooling Coil Size
2 tons	3½ ton
3 tons	4 ton
3½ - 5 tons	5 ton

Below is a reproduction of the label affixed to the evaporator coil compartment access cover on the NightBreeze unit. Installers are cautioned to observe the UL Listing or Recognition and rated evaporator coil design pressure requirements. Installers are responsible for filling in the charge date and refrigerant and oil type blanks at the bottom of the label

<u>IMPORTANT!</u>	
Refrigerant condensers, coils and all related cooling components incorporated in NightBreeze Systems must be properly sized in accord with the NightBreeze System Installation Manual and must be Listed or Recognized compliant with UL Standard 1995.	
Rated evaporator coil design pressure must be not less than the design pressure marked on the compressor or condensing unit	
<i>To Be Completed By Installer After Refrigerant Charging:</i>	
Initial system charge date:	_____
Refrigerant type:	_____
Oil type:	_____
<i>(Permanent Marker Required For Valid Warranty)</i>	

Heat Source Sizing and Water Temperature

The heat source must have sufficient heating capacity to accommodate the space heating load. For combined systems that use the same heat source for space heating and domestic hot water, the heat source must be sized for both loads. The heat source must also be capable of delivering hot water at the required temperature (see Table 2). For combined

systems, if the temperature requirement exceeds 130°F a hot water mixing valve or other means of limiting domestic hot water temperature must be provided to prevent scalding.

WARNING!

Maximum allowable hot water coil inlet temperature is 150°F

Hot Water Piping

Locating the air handler close to the water heater or boiler will save piping costs and reduce pipe heat loss. Increase pipe size from ¾" to 1" if the total equivalent length of piping exceeds 50 feet. Insulate all piping with ¾" thick molded foam insulation. Observe the flow direction indicated at the air handler water connections. Refer to water heater/boiler manufacturer instructions for connections. The heat source should be capable of producing at least 140°F water. Refer to Table 3 for heating ratings.

Control Placement

Outdoor Temperature Sensor: Proper placement of the outdoor temperature sensor is very important to assure proper control operation and temperature readings. Always locate it on the north side of the building where it will be shaded from direct sunlight. Avoid placement above a roof or adjacent to a west or northwest facing wall, or anywhere where hot air might collect. If two NightBreeze units are installed, always position the outdoor sensors in the same location.

Thermostat: Locate the wall display unit (thermostat) on an interior wall, near the return air grille. For two story residences install the thermostat on the second floor.

INSTALLATION

Preparation and Scheduling

Prior to Rough-In

1. Select and coordinate mounting locations for air handler and damper.
2. Select and coordinate size and location for the outside air intake with the builder/architect.
3. Determine main duct sizes and how they will be routed.
4. Size branch ducting using ACCA Manual D or other recognized methods.
5. Verify the heat source has sufficient capacity to meet all heating needs (space heating, plus domestic hot water if a combined system is used).
6. Prepare a piping diagram for connections between the heat source and the air handler(s).
7. Select location for pump and pump relay.
8. Coordinate piping and wiring requirements with plumber and electrician.

Rough-In

1. Install air handler, damper box, and ducting. Note that the damper assembly may be removed from the damper box during construction to prevent it from being coated by texture and paint.
2. Install control wiring from the air handler to the thermostat, outdoor sensor, damper, and pump locations.
3. Install or coordinate hot water piping between heat source, pump, and air handler.
4. Install refrigerant lines and control wiring between air handler and condensing unit location.

5. Coordinate power wiring to air handler and pump with electrician.

Finish

1. Mount damper mechanism in damper box and connect wiring.
2. Install and wire thermostat and outdoor temperature sensor.
3. Install and wire pump and pump relay.
4. Install condensing unit (optional).
5. Verify water, refrigerant, and electrical connections.
6. Install air filter.
7. Test system.

Air Handler

Install the air handler on decking in an accessible attic or 2nd floor mechanical space. Conform to local codes for access and condensate drainage. Except for the access side, the cabinet is zero clearance and there are no combustion air or venting requirements. To minimize noise at the return grille, connect the air handler to the damper using at least 5' of appropriate size flex duct (see Duct Sizing Recommendations table). The air handler may either be mounted in a horizontal, up-flow, or down-flow configuration. Optional side and bottom cut-outs may be made for installation in side or bottom return applications (see Fig. 2).

Damper

An exploded view of the damper is provided in Figure 7. The damper mounts immediately above the return air grille with the flanged side down. Up to 18" round openings may be cut for duct connections (see Fig. 3 for locations). For ducts larger than 18" either use oval collars or provide appropriate adapters. Refer to Table 4 for sizing outside air ducting; the duct connecting to damper to the air handler must be the same size.

The side of the damper opposite the barometric relief opening connects to the air handler. The top opening connects to the outside air intake. Note that the damper has only one correct installed position. The damper mechanism may be removed from its duct board enclosure and stored in a safe place to avoid damage during construction. Provide a 20" x 30" hinged filter grille for access to the filter, which mounts in a vertical slot inside the damper. The filter grille flange must be notched to allow the filter to slide in and out freely. The damper accommodates a 20" x 30" x 1" filter. 3M Filtrete[®] 1000 or 1250 filters, or equivalent are recommended.

IMPORTANT

Do not move damper blade manually. This will damage motor/gear assembly.

Figure 7: Exploded View of Damper

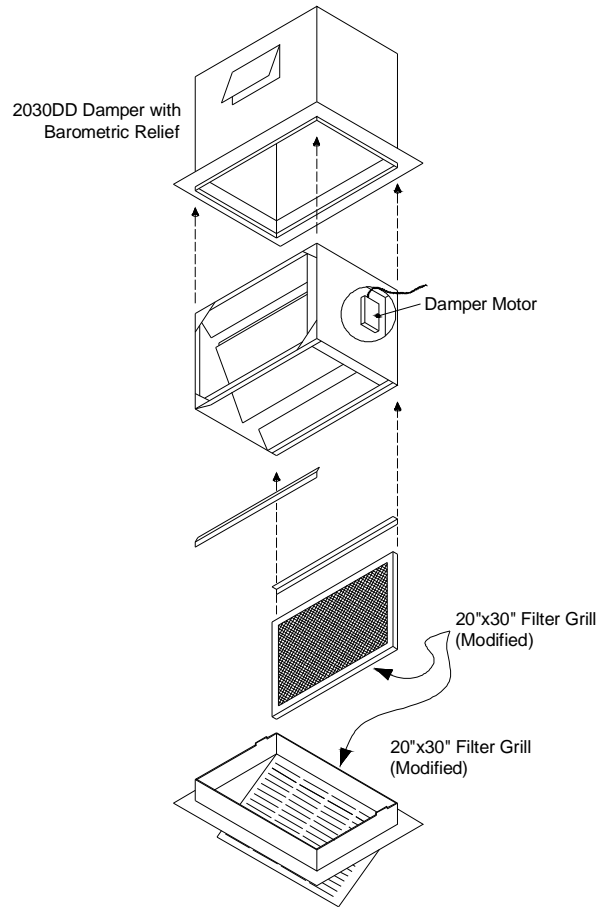

Wiring

Air Handler Power: Install a disconnect switch at the air handler. Connect hot, neutral, and ground wires to the black, white, and green wires in the air handler power wiring box as shown in Figure 4. Note that the two black and two white wires in the box must be wired together with the power leads. Provide appropriate strain relief or conduit as required by code.

IMPORTANT

All wiring shall be in accordance with local and national electrical codes.

The blower motor is continuously powered. Allow 5 minutes after disconnecting power for capacitors to discharge before servicing the motor.

Controls: Use 4-conductor 18 gauge thermostat wire to connect the thermostat, outdoor temperature sensor, and damper to the air handler control terminals using the wiring conventions described in the following tables.

IMPORTANT

Controls utilize digital communications. Use only the thermostat provided with the system (TS36). Do not attempt to operate the system by jumpering control terminals, and **do not** connect controls to an external low voltage power source.

Table 7 THERMOSTAT WIRING		
Thermostat (terminals labeled "CU")	Connecting Wire Color	Air Handler (terminals labeled "Thermostat")
-	Green	Gnd
+	Red	+V
C	Black or Blue	CK
D	White	DT

Table 8 OUTDOOR SENSOR WIRING		
Outdoor Temperature Sensor	Connecting Wire Color	Air Handler (terminals labeled "Outside Sensor")
G	Green	Gnd
+V	Red	+V
C	Black or Blue	CK
D	White	DT

Table 9 DAMPER WIRING		
Damper (wire color)	Connecting Wire Color	Air Handler (terminals labeled "Damper")
White (3)	White	Open
Green (2)	Green	Close
Red (1)	Red	Com

Pump Power and Relay: Install a junction box near the pump for mounting the pump relay. Wire the pump to the pump relay as shown in Fig. 8, and connect the low voltage control wire from the air handler to the low voltage inputs to the relay. The air handler pump control terminal block is located apart from the other terminals just below the transformer.

Condenser Wiring: Connect the condenser control wires to the C and Y1 terminals at the air handler terminal block. The output from these terminals is 24 VAC (not dry contact).

Note: This model is not configured for a two speed condenser - Y2 is not operative.

Figure 8 - Wiring Diagram

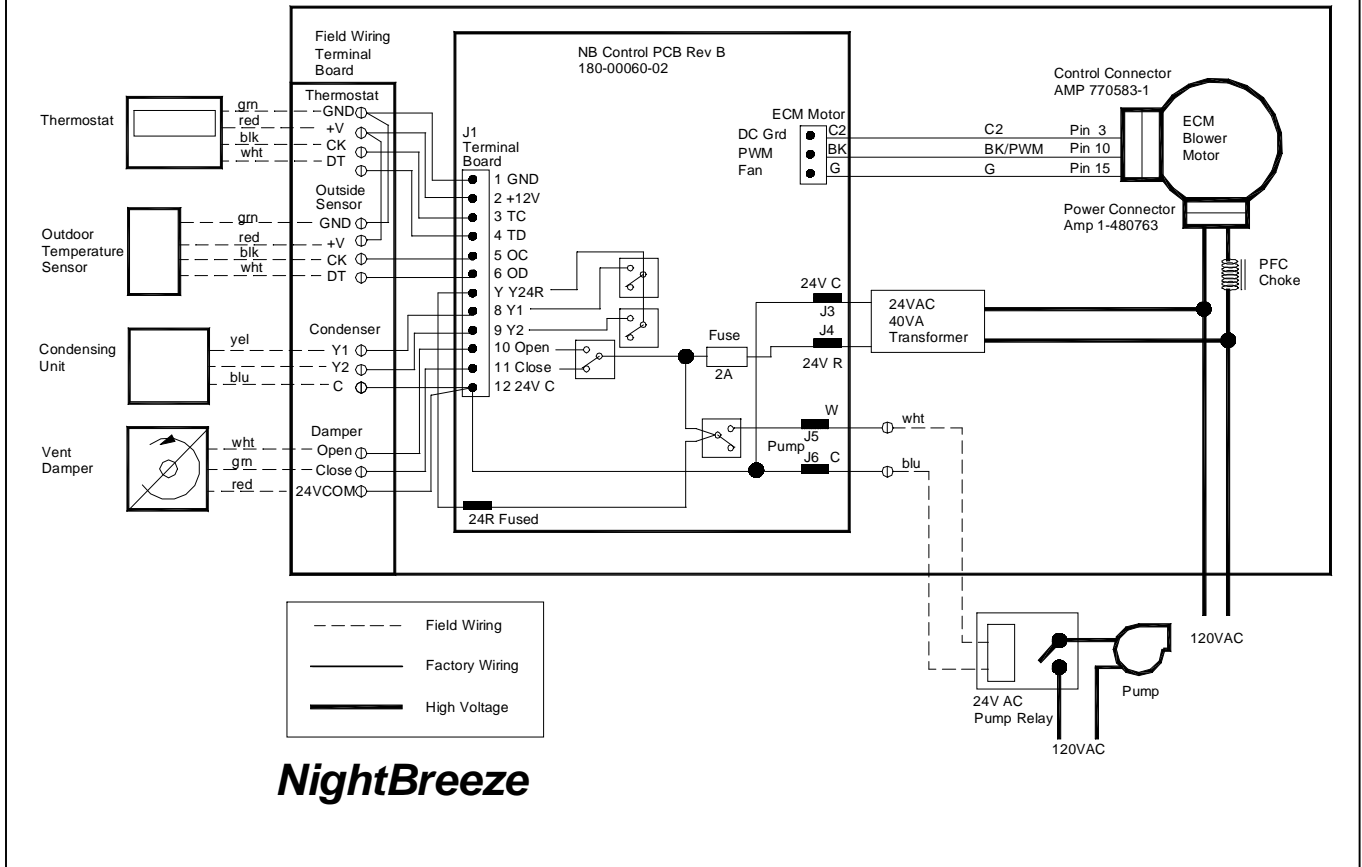

Note: The installer must connect the two wires from the transformer with the two wires to the fan motor to the two power leads (white-to-white and black-to-black).

Pump Selection and Installation

Because of the wide variation in flow and pressure encountered in different installations, a pump is not provided with the NightBreeze system. The pump must be sized for the design flow (determined using Table 3) and the total system pressure drop, including the heat source, heating coil (from Table 3), and piping. Especially when using tankless, or instantaneous, water heaters be sure to consult manufacturer’s literature for pump sizing for combined heating applications.

A pump relay is provided in the NightBreeze parts kit. The relay should be located close to the pump and wired as shown in Figure 4.

Piping

The air handler coil may be connected to either a potable water system or a closed-loop pressurized system. Install 3/4" copper or PEX (if approved) piping between the water heater or boiler and the air handler (1" is recommended if the total piping length exceeds 100 ft.) Provide an air vent near the fan coil to remove air from the piping as needed. To facilitate

flushing the piping and future service needs, provide isolation valves and a drain at the connections to the hot water source, and unions at the connections to the air handler.

Figure 5 provides an example of how piping should be installed for most tankless water heaters. Tempering valves are required whenever the hot water temperature required for the air handler exceeds 130°F (see Table 2). Be sure to select a tankless water heater model that is approved by the manufacturer for combined heating/domestic water heating applications.

IMPORTANT!

Avoid running piping in locations where it could potentially freeze, or provide suitable freeze protection.

Insulate all piping with ¾" or thicker molded foam pipe insulation.

Flush piping to remove contaminants prior to connecting to domestic hot water system.

CONTROL SETUP

Advanced Settings

IMPORTANT!

Airflow rates and other permanent control settings must be completed before turning the system over to the owner.

Follow these instructions carefully:

1. Press the *Mode* button on the thermostat until *Off* is displayed.
2. Hold down the two arrow buttons to the right of the display simultaneously until the *Advanced Settings* menu appears.
3. Use the up/down arrow buttons to select the menu item and the - / + buttons to adjust the settings. The table below explains each setting.
4. When finished, press the button marked *Done*.

Comfort Range Settings: The NightBreeze system regulates the amount of ventilation cooling provided by automatically varying both the indoor temperature at which ventilation cooling is terminated and the airflow rate. There are 10 different comfort settings to meet the needs of the owner. The default setting is 0. The control strategy behind the warmest (+5), coolest (-5), and average (0) settings are as follows:

Setting = -5: The system always attempts to vent the house down to the low limit setting.

Setting = +5: The system attempts to provide just enough ventilation cooling so that the house will not be warmer than the high limit (air conditioner) setting.

Setting = 0: The system attempts to maintain the indoor temperature range between the low limit and high limit settings.

**Table 10
ADVANCED CONTROL SETTINGS**

Menu Item	Description	Recommended Setting
Comfort Adjust	Preferred comfort range (-5 to +5). See Comfort Range Settings for explanation)	0 (default)
Vent Delta Temp	Indoor-outdoor temperature difference at which ventilation cooling will be initiated, °F. (0-9)	5 (default)
Tout Offset	Outdoor temperature sensor calibration, °F. (-9 to +9)	0 or calibrate
Tin Offset	Indoor temperature sensor calibration, °F. (-9 to +9)	0 or calibrate
AC Mode	Air conditioner operating mode (Standard, Precool, or None)	<i>Standard</i> if AC installed (default) <i>None</i> if no AC installed <i>Precool</i> (disabled)
AC on Delay	Time delay between condensing unit cycles, minutes. (0 to 5)	0 if condensing unit has built-in time delay, or 5 if it doesn't
Man Fan Time	Length of time fan will run when the <i>Fan</i> button is pressed, hours. (0 to 4)	1 (default)
AC Fan CFM	Airflow for air conditioner operation, CFM (100 to 2100)	See Table 12
Ventilation Rate	Average hourly airflow rate for heating mode fresh air ventilation, CFM. (0 to 95)	See Table 11
Vent Fan CFM	Maximum airflow for ventilation cooling, CFM (100 to 2200)	See Table 11
Heat Fan CFM	Maximum fan speed for heating operation, CFM. (100 to 2200)	See Table 12
Man Fan CFM	Maximum fan speed for manual fan operation	See Table 11

Sensor Calibrations: Both the indoor (thermostat) and outdoor air temperature sensors should be calibrated using advanced control settings at time of installation. To calibrate the sensors use an accurate handheld digital thermometer to measure air temperature in close proximity to the thermostat and the outdoor temperature sensor. If the measured temperature is lower than the temperature displayed by the thermostat, enter a negative offset, and vice versa. For example, if the thermostat reads 70° indoor temperature and the measured temperature is 72°, enter a +2 next to *Tin Offset*. Be sure to allow adequate time for the handheld thermometer to equilibrate to ambient temperatures before taking readings.

Airflow Settings: Set airflow rates in *Advanced Settings* to values in Tables 11 and 12.

IMPORTANT!

Proper airflow settings are necessary to insure correct system operation and optimal performance.

Table 11 RECOMMENDED VENTILATION RATE SETTINGS			
House Size (ft ²)	Vent Fan CFM	Manual Fan CFM	Heating Ventilation Rate
Up to 1400	800	600	15 CFM / bedroom + 15 CFM
1400 - 1800	1000	800	15 CFM / bedroom + 15 CFM
1800 - 2200	1300	1000	15 CFM / bedroom + 15 CFM
2200 - 2600	1600	1200	15 CFM / bedroom + 15 CFM
2600 - 3000	1800	1400	15 CFM / bedroom + 15 CFM

Table 12 HEATING AND COOLING CFM SETTINGS			
HEATING		COOLING	
Heating Load (Btu/hr)	Heat Fan CFM	AC Size (tons)	AC Fan CFM
20,000	600	1-1/2	600
30,000	800	2	800
40,000	1000	2-1/2	1000
50,000	1200	3	1200
60,000	1400	4	1600
70,000	1600	5	2000

When all advanced settings have been entered, press *Done*.

Basic User Settings

Setting the Clock: If the thermostat clock does not display the correct time, select *Off* mode and press the *Clock* button. Use the ← and → buttons to position the cursor under the time or date digits you want to change, and use the up/down buttons to the right of the display to change the setting.

Temperature Settings: Refer to the Owner's Manual for information on changing temperature settings, and/or use the *Help* button.

Note: If the outside temperature displays 00, disconnect and restore power to the air handler. This will occur if the thermostat is removed from its wall plate and replaced without first cutting power.

STARTUP

1. Apply power to the air handler.
2. Verify that the thermostat display is lighted.
3. Follow instructions in **CONTROL SETUP** for configuring control settings.
4. Verify that the hot water source (boiler or water heater) is operational. Refer to Table 2 for recommended water temperature settings.

IMPORTANT!

For combined systems using water temperature settings greater than 130°F provide a suitable mixing valve to prevent potential scalding.

5. Purge all air from piping.

6. At the thermostat select *Heat* mode and press the *Up* button until the set temperature exceeds the indoor temperature by about 2°.
7. The Fan and Heat indicator lights should light, and the fan and pump should start. Verify that hot water is circulating to the heating coil.
8. If air conditioning is installed, verify condenser operation by selecting *Cool* mode and activate cooling by pressing the *Down* button until the set temperature is about 2° lower than the indoor temperature.
9. The Fan and A/C lights should light. Verify that the condenser is operating.
10. Verify damper operation by pressing the *Fan* button (from either *Heat* or *Cool* mode) twice. The squiggly arrow will indicate that the system is bringing in outdoor air (a circular arrow indicates that air is being recirculated). The *Fan* light should light; visually inspect the damper through the relief opening to insure the damper changes position to admit outdoor air.
11. Refer to **TROUBLESHOOTING** if the system fails to operate properly.

Figure 9: Piping Example for Tankless Water Heaters

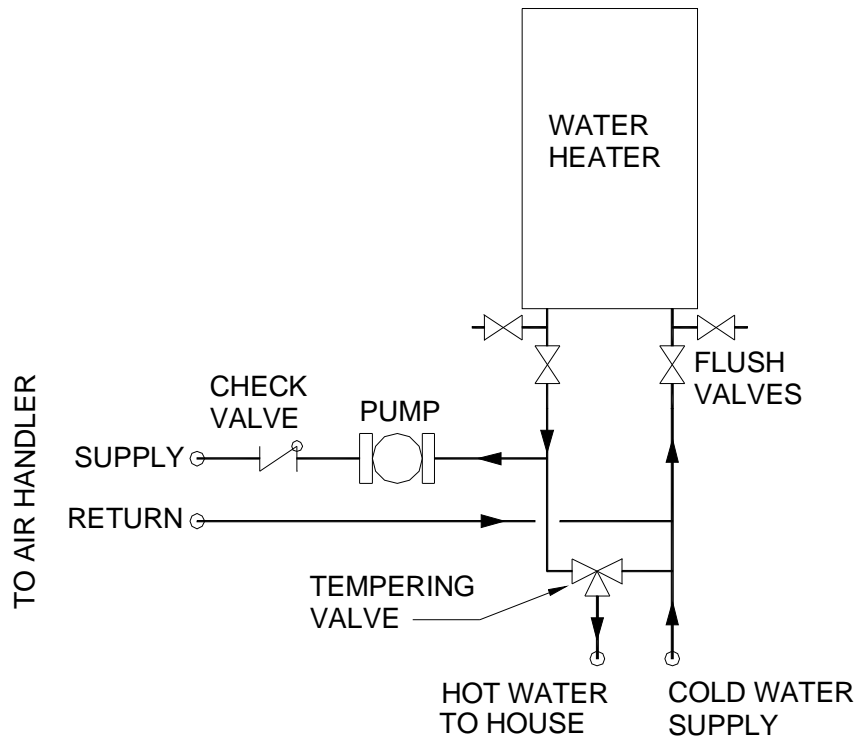

Notes: A tempering valve may not be required if the water temperature recommended in Table 2 is 140°F or less.

The pump must be sized for the combined pressure drop of the coil (from Table 3), the pressure drop through the water heater (obtain from the manufacturer) and piping and fitting pressure drop. For most tankless water heater applications a Taco 009BF-5 or Grundfos UP26-96BF is suitable.

TROUBLESHOOTING

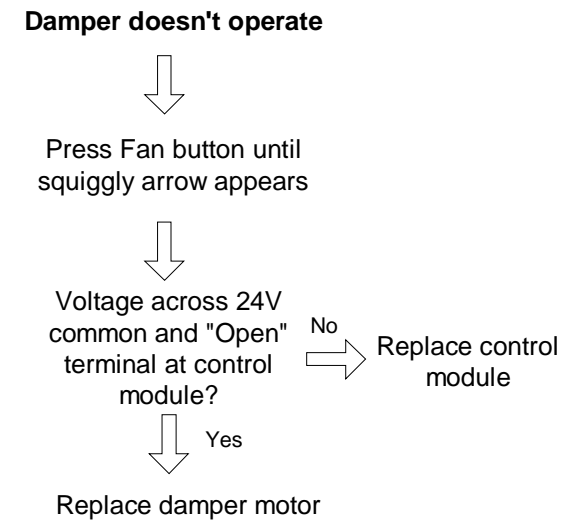
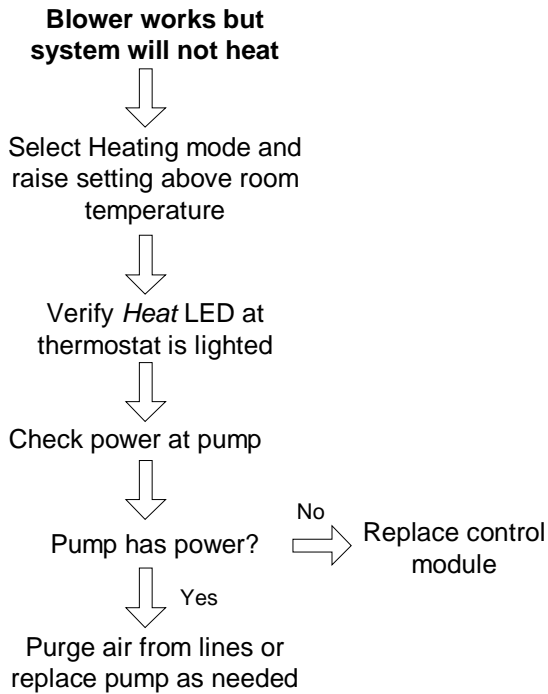
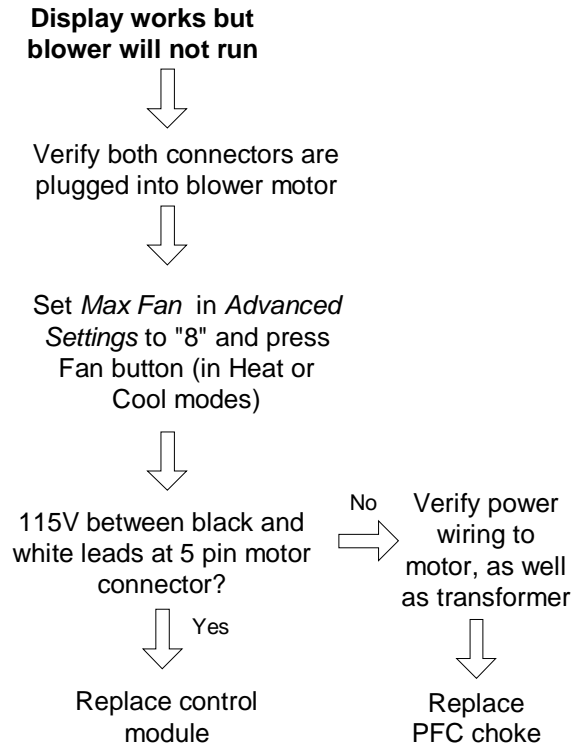
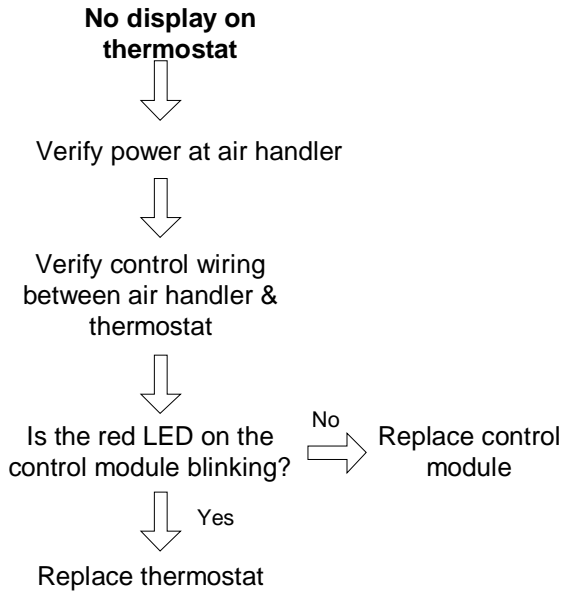

**Advanced Energy
Products**
NIGHTBREEZE[®]

Model NB10-2-120A
Variable Speed Ventilating Hot Water Air Handler
STANDARD LIMITED PRODUCT WARRANTY

Please read the following Warranty carefully. Advanced Energy Products (AEP) provides a Standard Warranty on parts-only as detailed below. Any labor or service warranty provided or implied by your installer or serviceman is provided by him and not by AEP.

You should be sure the information provided for following the Warranty text is completed for your records and future use.

ONE YEAR WARRANTY: NIGHTBREEZE Systems are warranted to be free of all defects in material and workmanship under normal use and maintenance for a period of one (1) years from the date of initial operation in accordance with the terms of this Warranty. This Warranty applies only to the System in its original installation location and is void if the System is reinstalled elsewhere.

AEP will repair or replace any part of the System, which fails in normal use and service within one (1) years from the date of initial operation, in accordance with the terms of this Warranty. Exchanged parts or repairs will be warranted for only the unexpired portion of the original Warranty.

SHIPPING COSTS: Only one-way shipping costs will be paid for by AEP to (or, at its option, from) a convenient delivery point selected by AEP near the place of installation from (or to) the nearest AEP service location. Local cartage and all other transportation costs are the responsibility of the owner.

LABOR COSTS: This Warranty does not cover any labor expenses for service, nor for diagnosing, removing or reinstalling parts. All such expenses are the owner's responsibility, unless a labor service agreement exists between you and your installation contractor or AEP (contact AEP for information regarding separate labor service agreements which may be offered).

HOW TO OBTAIN WARRANTY PERFORMANCE: Normally, the installing contractor from whom the unit was purchased will be able to take necessary corrective action by obtaining replacement parts through AEP. If the installing contractor is not available, contact any other local contractor representing AEP Systems, or you may obtain replacement parts directly by contacting AEP at the following address:

AEP Corp., Attn: Warranty Claims
123 C Street, Davis, CA 95616
(530) 753-1100

HOWEVER, ANY REPLACEMENTS ARE MADE SUBJECT TO VALIDATION BY AEP OF IN-WARRANTY COVERAGE. An item to be replaced must be made available in exchange for the replacement.

THIS WARRANTY WILL NOT APPLY AND AEP WILL NOT BE RESPONSIBLE FOR: (1) Normal maintenance as outlined in the Owner's Manual or instructions; (2) Damage or repairs required as a consequence of faulty installation or application; (3) Failure to start due to voltage conditions, blown fuses, open circuit breakers, or other damages due to the inadequacy or interruption of electrical service; (4) Damage or repairs needed as a consequence of any abuse, improper servicing, unauthorized alteration or improper operation; (5) Damage as a result of floods, winds, fires, lightning, accidents, corrosive environments, or other conditions beyond the control of AEP; (7) Electricity or fuel

costs or increases in electricity or fuel costs from any reason whatsoever, including additional or unusual use of supplemental electric heat; (8) Any special, indirect, consequential, property, or commercial damage of any nature whatsoever.

LIMITATION ON WARRANTIES: OTHER THAN AS EXPRESSLY STATED HEREIN, ALL OTHER WARRANTIES, EXPRESS OR IMPLIED, INCLUDING WITHOUT LIMITATION, ALL IMPLIED WARRANTIES OF MERCHANTABILITY AND FITNESS FOR A PARTICULAR PURPOSE, ARE EXCLUDED. All work under the terms of this Warranty shall be performed during normal working hours. All replacement parts, whether new or remanufactured, assume as their warranty period only the remaining time period of this Warranty.

LIMITATION ON LIABILITY: IN THE EVENT THAT THERE IS ANY BREACH OF WARRANTY, THE OWNER'S SOLE AND EXCLUSIVE REMEDY IS REPAIR OR REPLACEMENT OF THE PARTICULAR DEFECTIVE ITEM WITHIN THE SYSTEM OR, AT THE OPTION OF AEP, RETURN OF THAT PORTION OF THE PURCHASE PRICE EQUAL TO THE FAIR MARKET VALUE OF THE COMPONENT WITHIN THE SYSTEM PRIOR TO ITS BECOMING DEFECTIVE. IN NO EVENT SHALL AEP BE LIABLE FOR CONSEQUENTIAL DAMAGES OF ANY KIND BEYOND THE PURCHASE PRICE OF THE SYSTEM. THIS LIMITATION ON CONSEQUENTIAL DAMAGES IS EFFECTIVE REGARDLESS OF THE THEORY OF LIABILITY OF THE SUING PARTY, WHETHER CONTRACT, TORT, OR OTHER LEGALLY PERMISSIBLE BASIS FOR ITS ACTION.

LICENSE: Any manuals, instructions, or other written materials supplied with the System remain the property of AEP. AEP hereby grants to owner (or owner's assignee) a non-exclusive, royalty-free license to use such information in connection with the System. The owner agrees to not copy or reproduce or provide to others any such materials without the express written consent of AEP.

OWNER COMPLIANCE: The owner agrees to comply with all the provisions and conditions relating to the care and operation of the System contained within any written materials. The owner understands and agrees that such compliance is an express condition precedent to any claim by owner that the System fails to satisfy the warranty obligation of AEP.

LIMITATION ON CLAIMS: In the event that the owner institutes a lawsuit against AEP, such lawsuit shall be filed and served within two (2) years from the date of the alleged breach or be forever barred.

NOTE: California law may not allow the exclusion or limitation of incidental or consequential damages nor limitations on how long an implied warranty lasts, so the above limitations may not apply to you.

AEP recommends you immediately record the information below and that you retain this Warranty Certificate in the event warranty service is needed. Reasonable proof of the effective date of the warranty must be presented; otherwise the effective date will be based upon the date of system manufacture plus 30 days.

OWNER NAME _____

Street Address _____

City/State/Zip _____

Model and Serial Number _____

Date of Initial Operation _____

Z:\AEP\NightBreeze Production\Manuals\Current\InstallMan AH 0104r7.doc